

Diaphragm valve DIASTAR Ten PVC-U
FC (Fail safe to close)
Unions with solvent cement sockets ASTM

Model:

- Double flow rate compared to predecessor
- One housing nut replaces four screws
- Rotating air connection at 90° intervals
- For easy installation and removal
- Short overall length

Option:

- Individual configuration of the valve (see diagram)
- Comprehensive range of accessories available
- PN16 available as a configuration

* PN: PTFE

Working Pressure: **one side**

* O-Ring material: FKM

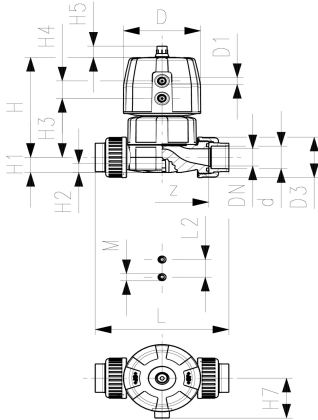

d	DN	Size	PN	PN*	kv-value	EPDM	SP	Weight
(mm)	(mm)	(inch)	(bar)	(bar)	($\Delta p=1$ bar)	Code		(kg)
					(l/min)			
20	15	½	10	10*	125	161 624 612	1	0.568
25	20	¾	10	10*	271	161 624 613	1	1.105
32	25	1	10	10*	481	161 624 614	1	1.343
40	32	1 ¼	10	10*	759	161 624 615	1	2.278
50	40	1 ½	10	10*	1263	161 624 616	1	3.951
63	50	2	10	6*	1728	161 624 617	1	4.661

FKM	PTFE/EPDM	SP	Weight
Code	Code		(kg)
161 624 662	161 624 632	1	0.602
161 624 663	161 624 633	1	1.113
161 624 664	161 624 634	1	1.361
161 624 665	161 624 635	1	2.308
161 624 666	161 624 636	1	3.975
161 624 667	161 624 637	1	4.643

D	D1_G	H	H1	H2	H3	H4	H5	H7	L	L2	M	z	Lift = Hx
(mm)	(inch)	(mm)	(mm)	(mm)	(mm)	(mm)	(mm)	(mm)	(mm)	(mm)		(mm)	(mm)
68	⅝	101	14	12	60	24	16	43	141	25	M6	96	7
96	⅝	132	18	12	73	25	16	57	165	25	M6	114	10
96	⅝	143	22	12	84	25	16	57	179	25	M6	122	13
120	⅝	173	26	15	99	26	26	69	204	45	M8	140	15
150	¾	214	32	15	119	36	26	88	230	45	M8	160	19
150	¾	226	39	15	132	36	26	88	268	45	M8	190	23

The technical data are not binding. They neither constitute expressly warranted characteristics nor guaranteed properties nor a guaranteed durability. They are subject to modification. Our General Terms of Sale apply.

Georg Fischer Piping Systems Ltd, Postfach, CH-8201 Schaffhausen/Switzerland

Phone +41 -(0)52-631 1111

e-mail: info.ps@georgfischer.com

Internet: <http://www.gfps.com>