

Pressure retaining valve type 586 PVC-C
Unions with solvent cement sockets metric
Without manometer

Model:

- Diaphragm PTFE/EPDM
- Integrated stainless steel mounting inserts
- 0.5-9.0 bar (7-130 psi)

0.3-3.0 bar (4-44 psi) on request
 Manometer on request

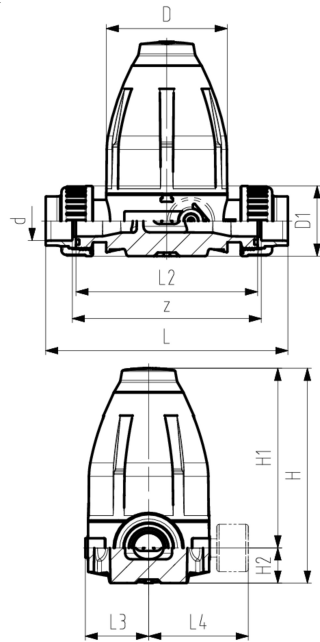

d (mm)	DN (mm)	Size (inch)	PN (bar)	O-rings EPDM Code	Weight (kg)	SP	GP	O-rings FKM Code
20	15	½	10	163 586 102	0.720	1		163 586 112
25	20	¾	10	163 586 103	1.560	1		163 586 113
32	25	1	10	163 586 104	1.600	1		163 586 114
40	32	1 ¼	10	163 586 105	4.360	1		163 586 115
50	40	1 ½	10	163 586 106	4.430	1		163 586 116
63	50	2	10	163 586 107	4.690	1		163 586 117

d (mm)	D (mm)	D1 (mm)	H (mm)	H1 (mm)	H2 (mm)	H3 (mm)	L (mm)	L2 (mm)	L3 (mm)	M	z (mm)	closest inch (inch)
20	79	43	132	111	21	12	162	120	42	M6	126	½
25	100	51	177	148	29	14	198	150	53	M6	156	¾
32	100	58	177	148	29	14	204	150	53	M6	156	1
40	147	72	251	207	44	21	267	205	76	M8	211	1 ¼
50	147	83	251	207	44	21	273	205	76	M8	211	1 ½
63	147	100	251	207	44	21	287	205	76	M8	211	2

The technical data are not binding. They neither constitute expressly warranted characteristics nor guaranteed properties nor a guaranteed durability. They are subject to modification. Our General Terms of Sale apply.

Georg Fischer Piping Systems Ltd, Postfach, CH-8201 Schaffhausen/Switzerland Phone +41 -(0)52-631 1111 e-mail:
 info.ps@georgfischer.com Internet: <http://www.gfps.com>