

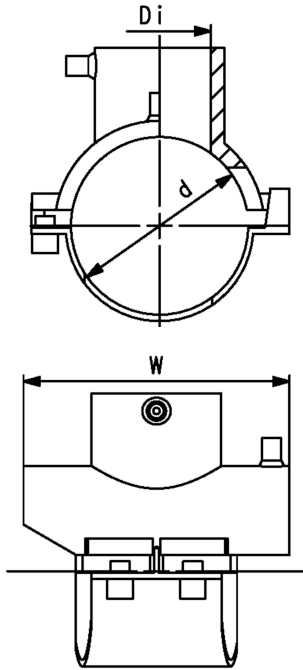

ELGEF Plus Electrofusion saddle PE100
d63-400mm / SDR11

- 10 bar Gas / 16 bar Water
- Complete with lower part
- 4 mm pin connectors
- Limited path fusion indicators
- In combination with parts of the modular System, the SDR compatibility is defined by the tapping-tees, tapping-valves and spigots with cutter.



d	Di	DN	PN	Code	Weight	W	Suitable for
(mm)	(mm)	(mm)	(bar)		(kg)	(mm)	
63	63	50	16	193 137 037	0.325	164	SDR Pipe 9-11
75	63	65	16	193 137 047	0.455	164	SDR Pipe 9-11
90	63	80	16	193 137 057	0.415	164	SDR Pipe 9-11
110	63	100	16	193 137 067	0.458	164	SDR Pipe 9-17.6
125	63	100	16	193 137 077	0.502	164	SDR Pipe 9-17.6
140	63	125	16	193 137 087	0.523	164	SDR Pipe 9-17.6
160	63	150	16	193 137 097	0.493	164	SDR Pipe 9-17.6
180	63	150	16	193 137 107	0.600	164	SDR Pipe 9-26
200	63	200	16	193 137 117	0.634	164	SDR Pipe 9-26
225	63	200	16	193 137 127	0.618	164	SDR Pipe 9-26
250	63	250	16	193 137 137	0.627	164	SDR Pipe 9-26
280	63	250	16	193 137 147	0.359	164	SDR Pipe 9-26
315	63	300	16	193 137 157	0.373	164	SDR Pipe 9-33
355	63	350	16	193 137 167	0.373	164	SDR Pipe 9-33
400	63	400	16	193 137 177	0.356	164	SDR Pipe 9-33

The technical data are not binding. They neither constitute expressly warranted characteristics nor guaranteed properties nor a guaranteed durability. They are subject to modification. Our General Terms of Sale apply.

Georg Fischer Piping Systems Ltd, Postfach, CH-8201 Schaffhausen/Switzerland Phone +41 -(0)52-631 1111 e-mail:
 info.ps@georgfischer.com Internet: <http://www.gfps.com>