

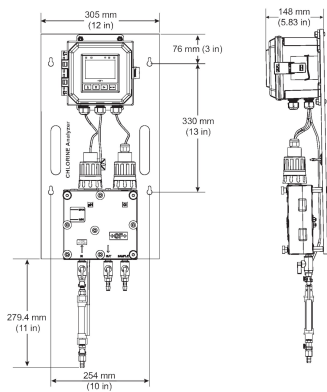

4630 Chlorine Analyzer System

Chlorine:

- EPA 334.0 Compliant
- Reagent free measuring
- Chemical Guard prevents over dosing of oxidants chemicals
- Built-in flow switch
- Chlorine and pH electrode performance data
- Automatic time stamp after successful calibration
- Customer enabled alarm feature for recalibration
- Complete panel system allows for quick and easy installation
- Built-in flow regulator maintains constant flow and pressure to the sensors regardless of inlet pressure
- Automatic pH compensation



MFR #	Description	Operating Range	Code
3-4630-13	Chlorine panel, free chlorine sensor (0.02 to 2 ppm) w/ sensor electronics, pH sensor w/ electronics, DC power input	0.02-2 ppm	159 001 949
3-4630-23	Chlorine panel, free chlorine sensor (0.05 to 5 ppm) w/ sensor electronics, pH sensor w/ electronics, DC power input	0.05-5 ppm	159 001 950
3-4630-33	Chlorine panel, free chlorine sensor (0.1 to 20 ppm) w/ sensor electronics, pH sensor w/ electronics, DC power input	0.1-20 ppm	159 001 951
3-4630-14	Chlorine panel, free chlorine sensor (0.02 to 2 ppm) w/ sensor electronics, pH sensor w/ electronics, AC power input	0.02-2 ppm	159 001 996
3-4630-24	Chlorine panel, free chlorine sensor (0.05 to 5 ppm) w/ sensor electronics, pH sensor w/ electronics, AC power input	0.05-5 ppm	159 001 997
3-4630-34	Chlorine panel, free chlorine sensor (0.1 to 20 ppm) w/ sensor electronics, pH sensor w/ electronics, AC power input	0.1-20 ppm	159 001 998

The technical data are not binding. They neither constitute expressly warranted characteristics nor guaranteed properties nor a guaranteed durability. They are subject to modification. Our General Terms of Sale apply.

Georg Fischer Piping Systems Ltd, Postfach, CH-8201 Schaffhausen/Switzerland Phone +41 -(0)52-631 1111 e-mail: info.ps@georgfischer.com Internet: <http://www.gfps.com>