

**Diaphragm valve DIASTAR Ten PVC-U
DA (Double acting)
Unions with threaded sockets NPT**

Model:

- Double flow rate compared to predecessor
- One housing nut replaces four screws
- For easy installation and removal
- Short overall length

Option:

- Individual configuration of the valve
 - 232 PSI available as a configuration
- * O-Ring material: FKM

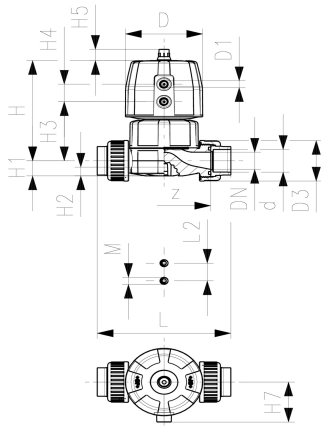

d (mm)	DN (mm)	Thread Type	Size (inch)	PN (bar)	PN (bar)	Cv-value (l/min)	PTFE/EPDM Code	SP	weight (kg)
20	15	NPT	½	10	10*	125	161 654 732	1	0.534
25	20	NPT	¾	10	10*	271	161 654 733	1	0.924
32	25	NPT	1	10	10*	481	161 654 734	1	1.161
40	32	NPT	1 ¼	10	10*	759	161 654 735	1	1.822
50	40	NPT	1 ½	10	10*	1263	161 654 736	1	3.032
63	50	NPT	2	10	10*	1728	161 654 737	1	3.983

D (mm)	D1_G (inch)	H (mm)	H1 (mm)	H2 (mm)	H3 (mm)	H4 (mm)	H5 (mm)	H7 (mm)	L (mm)	L2 (mm)	M	z (mm)	Lift = Hx (mm)
68	⅝	101	14	12	60	45	16	43	128	25	M6	96	7
96	⅝	132	18	12	73	25	16	57	152	25	M6	114	10
96	⅝	143	22	12	84	25	16	57	166	25	M6	122	13
120	⅝	173	26	15	99	26	26	69	192	45	M8	140	15
150	¾	214	32	15	119	36	26	69	222	45	M8	160	19
150	¾	226	39	15	132	36	26	69	266	45	M8	190	23

The technical data are not binding. They neither constitute expressly warranted characteristics nor guaranteed properties nor a guaranteed durability. They are subject to modification. Our General Terms of Sale apply.

Georg Fischer Piping Systems Ltd, Postfach, CH-8201 Schaffhausen/Switzerland Phone +41 -(0)52-631 1111 e-mail: info.ps@georgfischer.com Internet: <http://www.gfps.com>