

**SYGEF Plus**  
**Diaphragm valve DIASTAR Ten**  
**FO (Fail safe to open)**  
**With butt fusion spigots metric**

**Model:**

- Material: PVDF-HP
- Double flow rate compared to predecessor
- One housing nut replaces four screws
- Rotating air connection at 90° intervals

**Option:**

- Individual configuration of the valve (see diagram)
- Comprehensive range of accessories available

Working Pressure: **one side**

\*O-ring material: FKM white

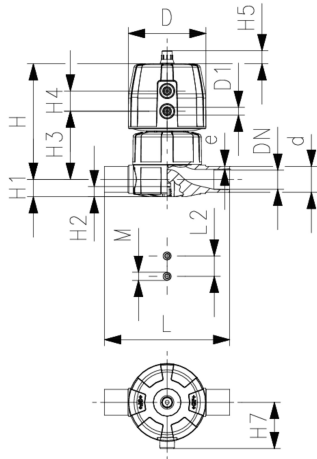

d (mm)	DN (mm)	PN (bar)	kv-value ( $\Delta p=1$ bar) (L/min)	PTFE/EPDM Code	Weight (kg)
20	15	10	125	<b>180 645 132</b>	0.618
25	20	10	271	<b>180 645 133</b>	1.016
32	25	10	481	<b>180 645 134</b>	1.222
40	32	10	759	<b>180 645 135</b>	1.882
50	40	10	1263	<b>180 645 136</b>	3.735
63	50	10	1728	<b>180 645 137</b>	4.545

d (mm)	D (mm)	D1_G (inch)	H (mm)	H1 (mm)	H2 (mm)	H3 (mm)	H4 (mm)	H5 (mm)	H7 (mm)	L (mm)	L2 (mm)	M (mm)	e (mm)	Lift = Hx (mm)
20	68	1/8	101	14	12	60	24	16	43	124	25	M6	1.9	7
25	96	1/8	132	18	12	73	25	16	57	144	25	M6	1.9	10
32	96	1/8	143	22	12	84	25	16	57	154	25	M6	2.4	13
40	120	1/8	173	26	15	99	26	26	69	174	45	M8	2.4	15
50	150	1/4	214	32	15	119	36	26	88	194	45	M8	3.0	19
63	150	1/4	226	39	15	132	36	26	88	224	45	M8	3.0	23

d (mm)	closest inch (inch)
20	1/2
25	3/4
32	1
40	1 1/4
50	1 1/2
63	2

The technical data are not binding. They neither constitute expressly warranted characteristics nor guaranteed properties nor a guaranteed durability. They are subject to modification. Our General Terms of Sale apply.

Georg Fischer Piping Systems Ltd, Postfach, CH-8201 Schaffhausen/Switzerland Phone +41 -(0)52-631 1111 e-mail:  
 info.ps@georgfischer.com Internet: <http://www.gfps.com>