

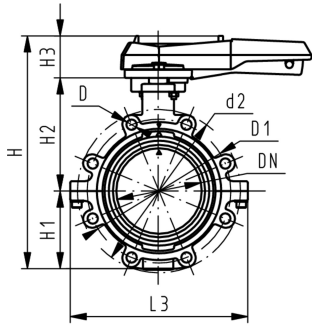

Type 568 Butterfly Valve PROGEF Standard Lever Operator

| Size (inch) | EPDM Part No. | FKM Part No. | weight (lb) |
|----------------|------------------|-----------------|----------------|
| 2 | 167 568 102 | 167 568 122 | 6.735 |
| 2 ½ | 167 568 103 | 167 568 123 | 7.489 |
| 3 | 167 568 104 | 167 568 124 | 8.318 |
| 4 | 167 568 105 | 167 568 125 | 14.407 |
| 5 | 167 568 106 | 167 568 126 | 16.898 |
| 6 | 167 568 107 | 167 568 127 | 24.220 |
| 8 | 167 568 108 | 167 568 128 | 32.307 |



| Size (inch) | d2 (mm) | D (mm) | D1 (mm) | H (mm) | H1 (mm) | H2 (mm) | H3 (mm) | L (mm) | L1 (mm) | L2 (mm) | L3 (mm) | Q1 (mm) | Q2 (mm) |
|----------------|------------|-----------|------------|-----------|------------|------------|------------|-----------|------------|------------|------------|------------|------------|
| 2 | 150 | UNC 5/8 | 121 | 265 | 77 | 134 | 54 | 45 | 106 | 205 | 150 | 40 | |
| 2 ½ | 170 | UNC 5/8 | 138 | 277 | 83 | 140 | 54 | 46 | 106 | 205 | 160 | 54 | 35 |
| 3 | 177 | UNC 5/8 | 152 | 289 | 89 | 146 | 54 | 49 | 106 | 205 | 175 | 67 | 50 |
| 4 | 216 | UNC 5/8 | 191 | 326 | 104 | 167 | 55 | 56 | 106 | 255 | 244 | 88 | 74 |
| 5 | 246 | UNC 3/4 | 216 | 353 | 117 | 181 | 55 | 64 | 106 | 255 | 272 | 113 | 97 |
| 6 | 273 | UNC 3/4 | 241 | 374 | 130 | 189 | 55 | 72 | 106 | 255 | 297 | 139 | 123 |
| 8 | 334 | UNC 3/4 | 298 | 435 | 158 | 210 | 67 | 73 | 140 | 408 | 360 | 178 | 169 |

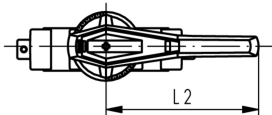
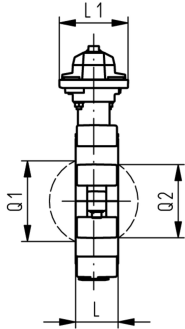

The technical data are not binding. They neither constitute expressly warranted characteristics nor guaranteed properties nor a guaranteed durability. They are subject to modification. Our General Terms of Sale apply.

Georg Fischer Piping Systems Ltd, Postfach, CH-8201 Schaffhausen/Switzerland

Phone +41 -(0)52-631 1111

e-mail: info.ps@georgfischer.com

Internet: <http://www.gfps.com>